

CATALOGO 2024 / CATALOGUE 2024





**GALTA**

# GT - S 400

**4.000 Kg**

 Ponte elettroidraulico a forbice da assetto

 Electro-hydraulic scissor lift bridge

 Elektrohydraulische Scherenhebebrücke

 Pont élévateur électro-hydraulique à ciseaux

 Puente elevador de tijera electrohidráulico



| DATI TECNICI              | TECHNICAL DATA          | TECHISCHE DATEN           | DONNÉES TECHNIQUES             |    |                     |
|---------------------------|-------------------------|---------------------------|--------------------------------|----|---------------------|
| Portata max.              | Max. capacity           | Max. Tragfähigkeit        | Portée max.                    | kg | 4000                |
| Portata max. LT           | Max. capacity LT        | Max. Tragfähigkeit LT     | Portée max. LT                 | kg | 3500                |
| Tempo di salita / discesa | Lifting / lowering time | Hubfahrt- / Senkfahrdauer | Temps de montée / descente     | s  | 50/48               |
| Alimentazione             | Power supply            | Stromversorgung           | Alimentation                   |    | 400V 3ph 50-60Hz    |
| Potenza motore            | Electric motor power    | Motorleistung             | Puissance du moteur            | kW | 2.6 (400V 3ph 50Hz) |
| Altezza sollevamento      | Lift height             | Höhe Aufzug               | Altura ascensor                | mm | 320-2170            |
| Tensione circuito comandi | Circuit voltage command | Leerlaufspannung Befehl   | Circuit de commande de tension | V  | 24                  |

- Parallelismo idraulico pedane e torrette
- Sicurezza idraulica in caso di sovraccarico
- Sicurezza idraulica/meccanica in caso di rottura tubi
- Pompa manuale di emergenza (OPTIONAL)
- Comandi uomo presente, 24V
- Serie 4 tamponi in gomma (ALT e SALT)

- Hydraulic parallelism of platforms and turrets
- Hydraulic safety in case of overload
- Hydraulic / mechanical safety in case of pipe breakage
- Emergency manual pump (OPTIONAL)
- Dead man controls, 24V
- Series 4 rubber pads (ALT and SALT)

- Hydraulische Parallelität von Plattformen und Türmen
- Hydraulische Sicherheit bei Überlastung
- Hydraulische / mechanische Sicherheit bei Rohrbruch
- Manuelle Notpumpe (OPTIONAL)
- Totmannkontrollen, 24V
- Gummipads der Serie 4 (ALT und SALT)

- Parallélisme hydraulique des plates-formes et tourelles
- Sécurité hydraulique en cas de surcharge
- Sécurité hydraulique / mécanique en cas de rupture de canalisation
- Pompe manuelle d'urgence (EN OPTION)
- Commandes homme mort, 24V
- Patins en caoutchouc série 4 (ALT et SALT)

- Paralelismo hidráulico de plataformas y torretas.
- Seguridad hidráulica en caso de sobrecarga.
- Seguridad hidráulica / mecánica en caso de rotura de tubería
- Bomba manual de emergencia (OPCIONAL)
- Controles de hombre muerto, 24V
- Serie 4 almohadillas de goma (ALT - SALT)



CONTROL UNIT  
CONTROL UNIT



4 LED LIGHTS  
4 LUCI A LED



DOUBLE EXTENSION 3T  
ESTENSIONI TORRETTA DOPPIA 3T



ROLLING JACK 2T / 3T  
ROLLING JACK 2T / 3T

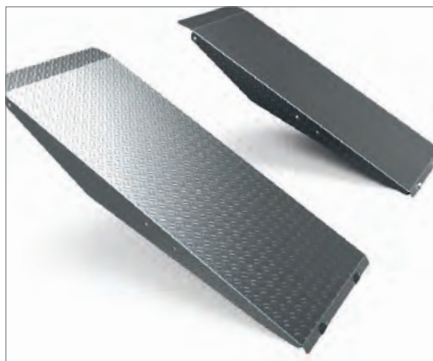

APPROACHING RAMPS  
RAMPE SALITA



SLIDING PLATES  
PIANI OSCILLANTI



PIATTO ROTANTE  
ROTATING PLATE



HPD 6 MOVEMENTS  
PROVA GIOCHI 6 MOVIMENTI

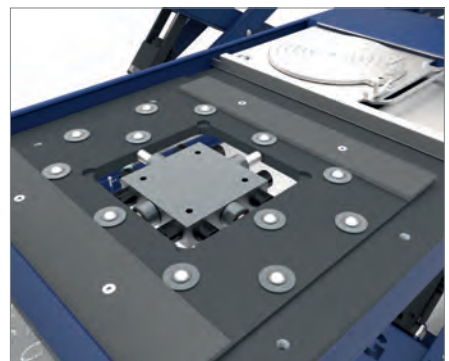

# S 400 ALT

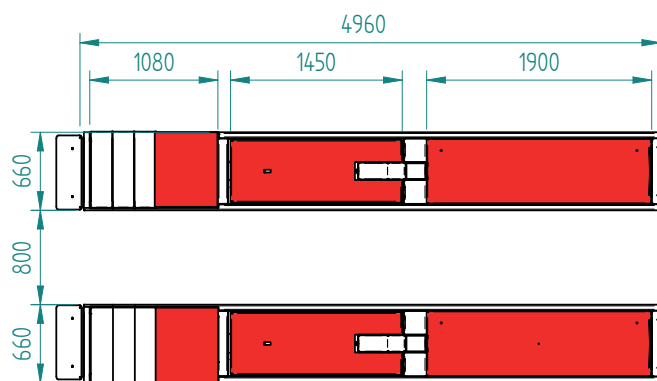
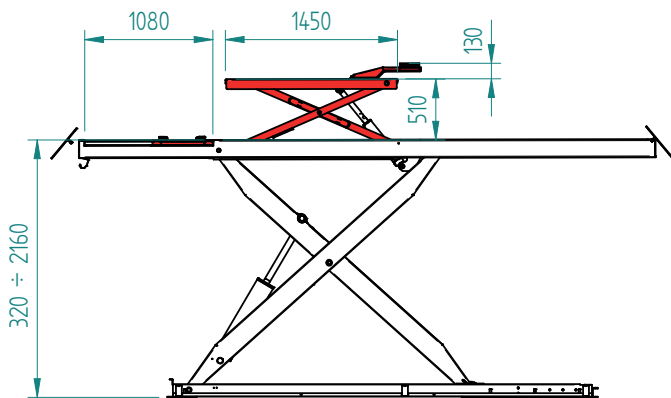

# S 400 A

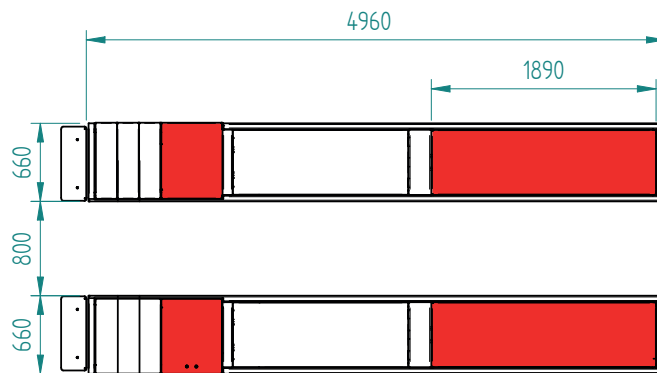
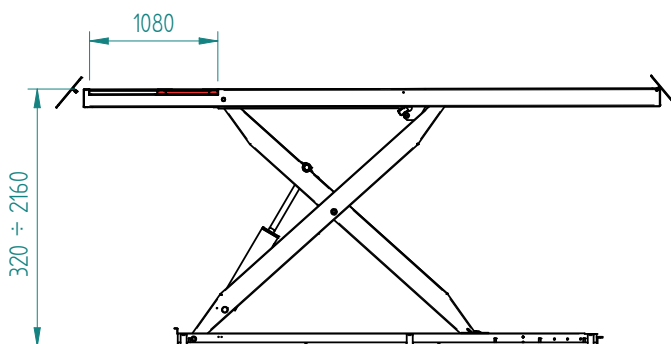

# S 400 SALT

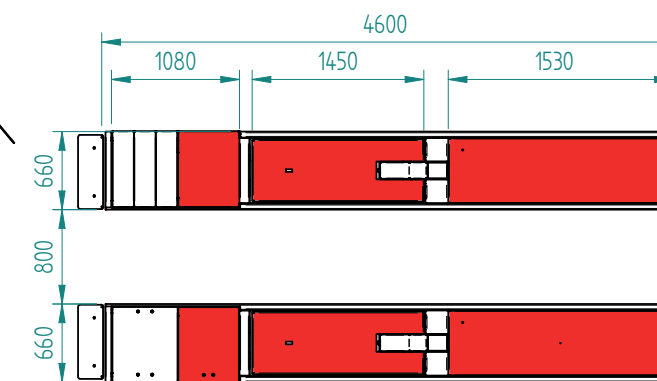
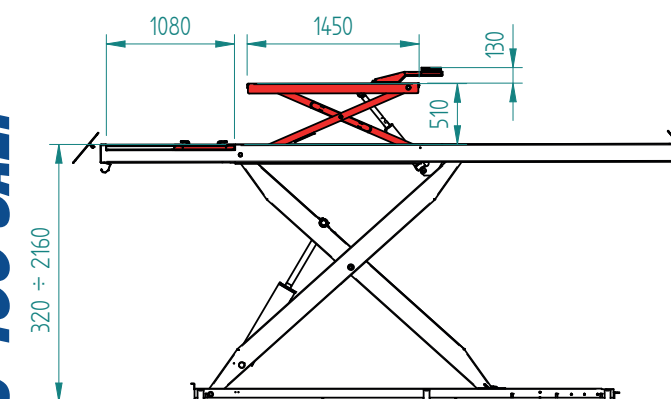

# S 400 SA

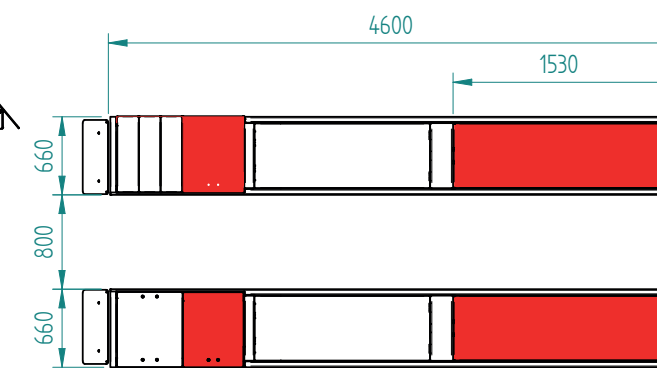
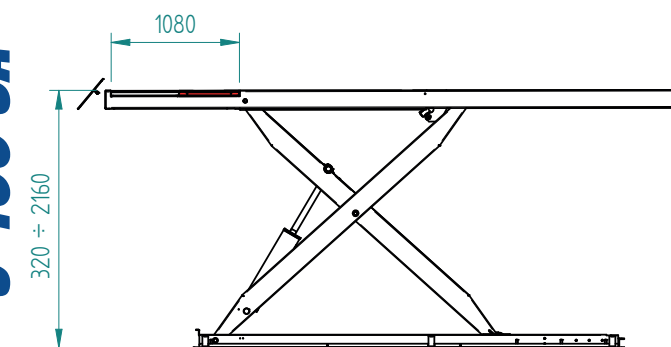

# S 400 F

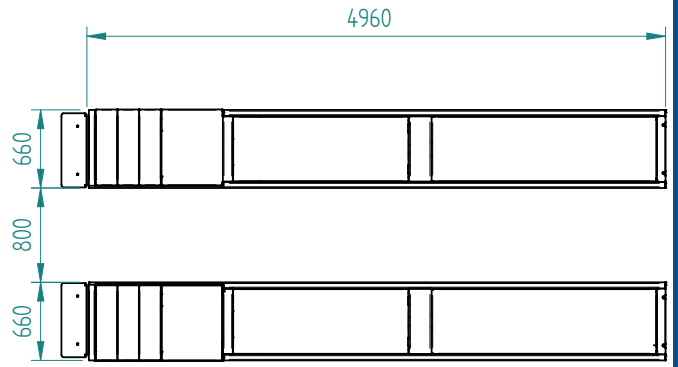
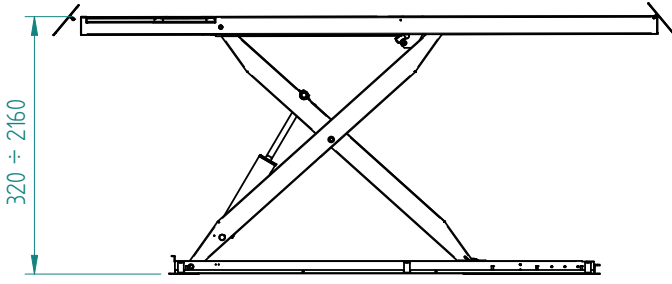

# S 400 SF

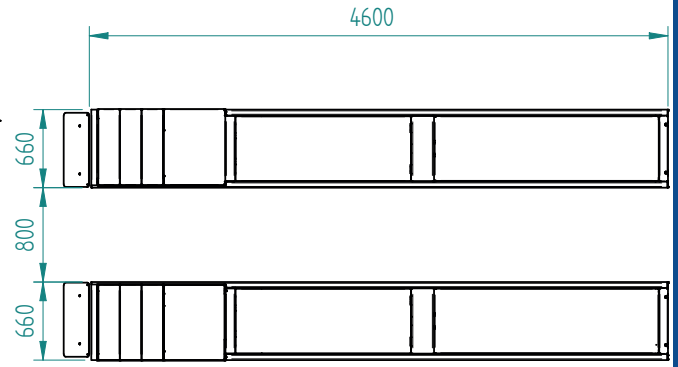
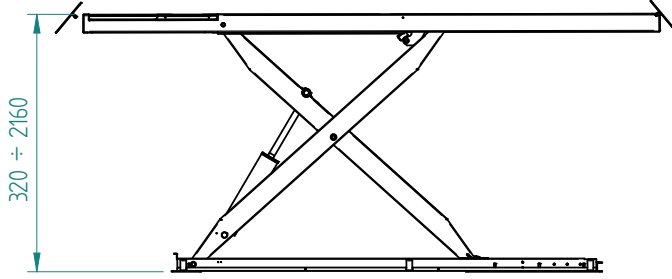

# S 400 FLT

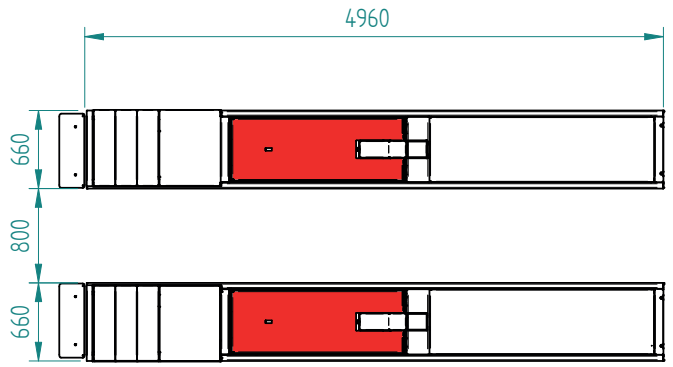
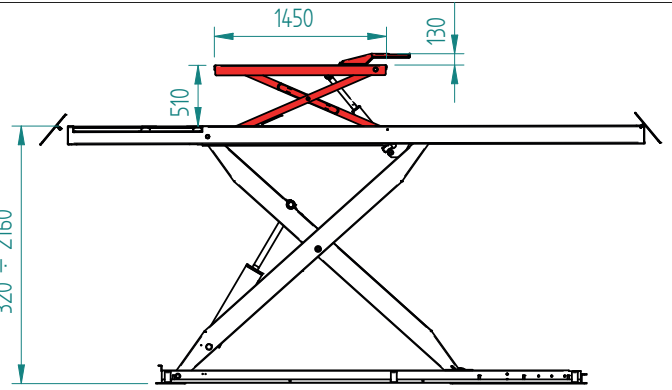

# S 400 SFLT

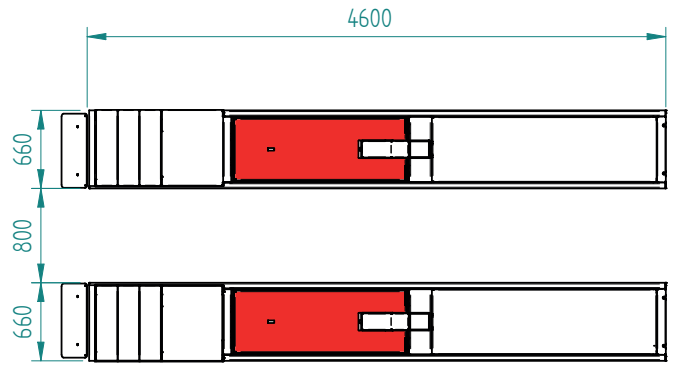
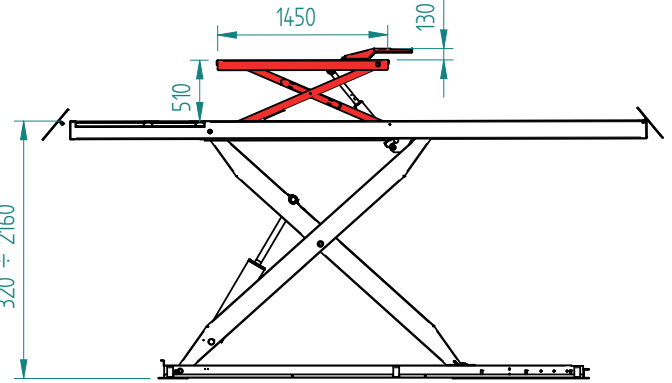

# OVERFLOOR

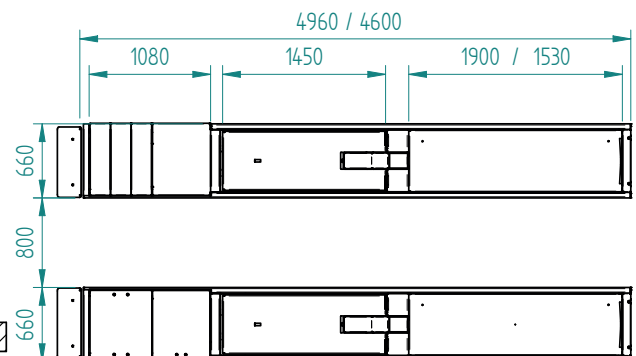
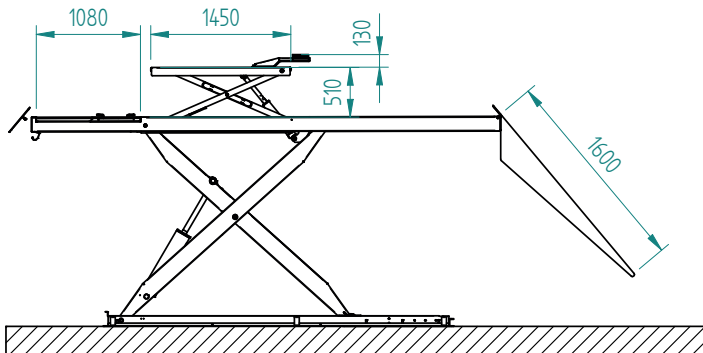



## OPTIONAL GT- S 400

| CODE           | DESCRIPTION  |  |
|----------------|--|--|
| <b>A-93013</b> | LED lamps 24 Volt - Set 4 lampade 24 Volt LED  |  |
| <b>A-93014</b> | Expansion bolts set (12 pz) - Set tasselli di fissaggio (12pz)   |  |
| <b>A-93014</b> | Approaching ramps for on ground installation - Set rampe salita per versione a pavimento   |  |
| <b>A-93016</b> | Mobile Cover for HPD - Coperture MOBILE vano HPD   |  |
| <b>A-93017</b> | Mobile Cover for TURNING PLATES - Coperture MOBILE vano PIATTI ROTANTI   |  |
| <b>A-93018</b> | Extension set for lift table (2 rubber pad included) - Set prolunghe per lift table (2 tamponi inclusi)                                  |  |
| <b>A-93019</b> | Set rubber pad H=60 mm (4 pz) - Set tamponi H=60 mm (4 pz)   |  |
| <b>A-93020</b> | Set rubber pad H=120 mm (4 pz) - Set tamponi H=120 mm (4 pz)   |  |
| <b>A-93024</b> | HPD 6 movements + spot light - HPD 6 movimenti + torcia  |  |
| <b>A-93025</b> | Turning plates set - Set piatti rotanti  |  |
| <b>A-93021</b> | Wires-pipes extension set L= +1 m - Set estensioni tubi-cavi L= +1 m   |  |
| <b>A-93022</b> | Wires-pipes extension set L= +2 m - Set estensioni tubi-cavi L= +2 m   |  |
| <b>A-93023</b> | Wires-pipes extension set L= +3 m - Set estensioni tubi-cavi L= +3 m   |  |
| <b>A-93026</b> | Wires-pipes extension set L=+1 m - Set estensioni tubi-cavi L= +1 m  |  |
| <b>A-93027</b> | Wires-pipes extension set L=+2 m - Set estensioni tubi-cavi L+2 m  |  |
| <b>A-93028</b> | Wires-pipes extension set L=+3 m - Set estensioni tubi-cavi L+3 m  |  |
| <b>A-93039</b> | Rubber ramps H=30mm - Rampe in gomma H=30mm  | ONLY FOR FLOOR VERSION / SOLO PER VERSIONE A PAVIMENTO |
| <b>A-93040</b> | Rubber ramps H=50mm - Rampe in gomma H=50mm  | ONLY FOR FLOOR VERSION / SOLO PER VERSIONE A PAVIMENTO |
| <b>A-93047</b> | control unit from right to left position<br>centralina da posizione destra a sinistra  |  |
| <b>A-93048</b> | control unit from right to left position with lift table<br>centralina da posizione destra a sinistra con lift table                     |  |
| <b>A-93049</b> | control unit from right to left without lift table but with HPD<br>centralina da posizione destra a sinistra senza lift table ma con HPD |  |
| <b>A-93050</b> | control unit from right to left position with lift table and HPD<br>centralina da posizione destra a sinistra con lift table e HPD       |  |
| <b>A-93057</b> | recessed structure for S400 S<br>struttura per incasso versione S400 S   |  |
| <b>A-93058</b> | recessed structure for S400<br>struttura per incasso versione S400   |  |



# GT-S 500

**5.000 Kg**

 Ponte elettroidraulico a forbice da assetto

 Electro-hydraulic scissor lift bridge

 Elektrohydraulische Scherenhebebrücke

 Pont élévateur électro-hydraulique à ciseaux

 Puente elevador de tijera electrohidráulico



| DATI TECNICI              | TECHNICAL DATA          | TECHISCHE DATEN           | DONNÉES TECHNIQUES             |    |                     |
|---------------------------|-------------------------|---------------------------|--------------------------------|----|---------------------|
| Portata max.              | Max. capacity           | Max. Tragfähigkeit        | Portée max.                    | kg | 5000                |
| Portata max. LT           | Max. capacity LT        | Max. Tragfähigkeit LT     | Portée max. LT                 | kg | 4000                |
| Tempo di salita / discesa | Lifting / lowering time | Hubfahrt- / Senkfahrdauer | Temps de montée / descente     | s  | 55/50               |
| Alimentazione             | Power supply            | Stromversorgung           | Alimentation                   |    | 400V 3ph 50-60Hz    |
| Potenza motore            | Electric motor power    | Motorleistung             | Puissance du moteur            | kW | 2.6 (400V 3ph 50Hz) |
| Altezza sollevamento      | Lift height             | Höhe Aufzug               | Altura ascensor                | mm | 350-2155            |
| Tensione circuito comandi | Circuit voltage command | Leerlaufspannung Befehl   | Circuit de commande de tension | V  | 24                  |



- Parallelismo idraulico pedane e torrette
- Sicurezza idraulica in caso di sovraccarico
- Sicurezza idraulica/meccanica in caso di rottura tubi
- Pompa manuale di emergenza (OPTIONAL)
- Comandi uomo presente, 24V
- Serie 4 tamponi in gomma (ALT e SALT)

- Hydraulic parallelism of platforms and turrets
- Hydraulic safety in case of overload
- Hydraulic / mechanical safety in case of pipe breakage
- Emergency manual pump (OPTIONAL)
- Dead man controls, 24V
- Series 4 rubber pads (ALT and SALT)

- Hydraulische Parallelität von Plattformen und Türmen
- Hydraulische Sicherheit bei Überlastung
- Hydraulische / mechanische Sicherheit bei Rohrbruch
- Manuelle Notpumpe (OPTIONAL)
- Totmannkontrollen, 24V
- Gummipads der Serie 4 (ALT und SALT)

- Parallélisme hydraulique des plates-formes et tourelles
- Sécurité hydraulique en cas de surcharge
- Sécurité hydraulique / mécanique en cas de rupture de canalisation
- Pompe manuelle d'urgence (EN OPTION)
- Commandes homme mort, 24V
- Patins en caoutchouc série 4 (ALT et SALT)

- Paralelismo hidráulico de plataformas y torretas.
- Seguridad hidráulica en caso de sobrecarga.
- Seguridad hidráulica / mecánica en caso de rotura de tubería
- Bomba manual de emergencia (OPCIONAL)
- Controles de hombre muerto, 24V
- Serie 4 almohadillas de goma (ALT - SALT)



CONTROL UNIT  
CONTROL UNIT



LIFT TABLE EXTENSION 3.5T  
ESTENSIONI TORRETTA 3.5T



LIFT TABLE DOUBLE EXTENSION 3.5T  
DOPPIE ESTENSIONI TORRETTA 3.5T



4 LED LIGHTS  
4 LUCI A LED

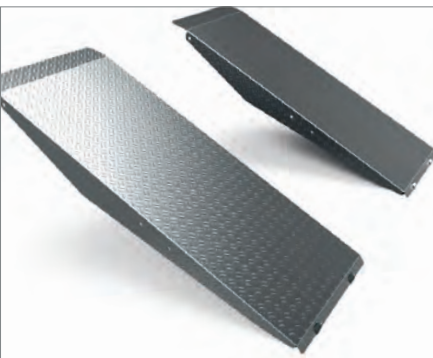

APPROACHING RAMPS 1600mm  
RAMPE SALITA 1600mm



SLIDING PLATES  
PIANI OSCILLANTI



PIATTO ROTANTE  
ROTATING PLATE



HPD 6 MOVEMENTS  
PROVA GIOCHI 6 MOVIMENTI

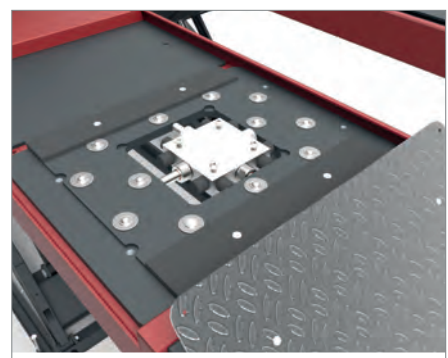

# S 500 ALT

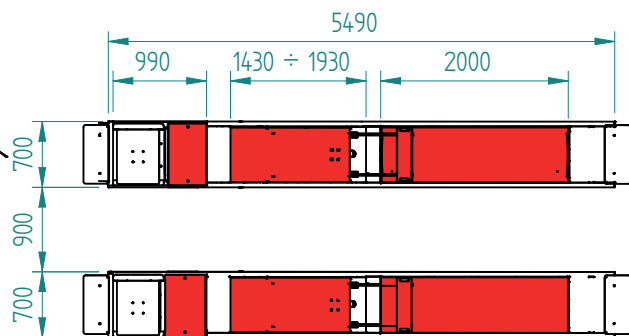
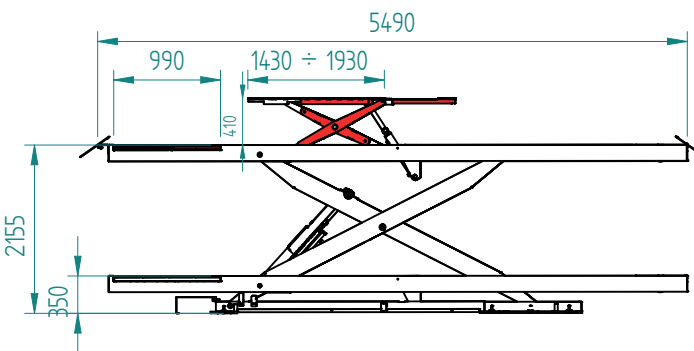

# S 500 A

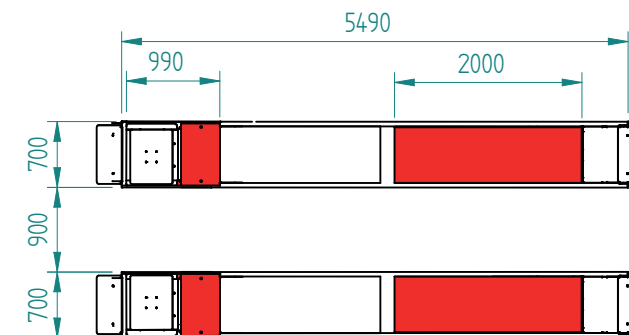
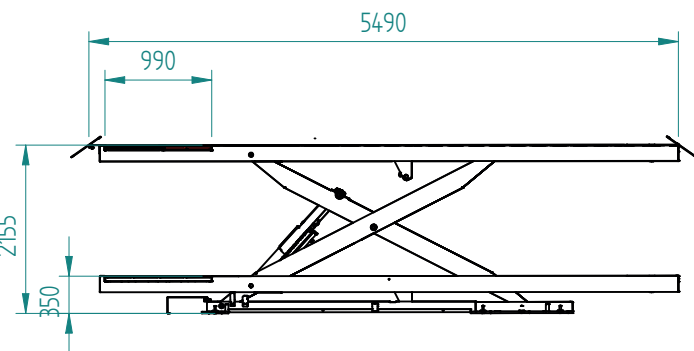

# S 500 SALT

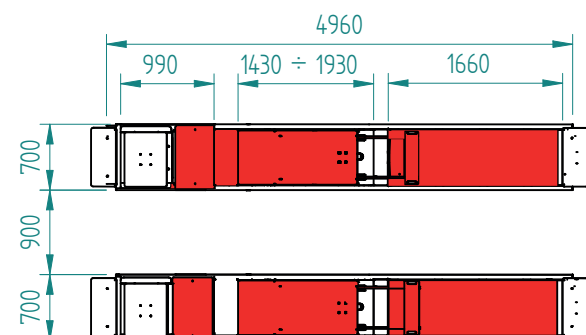
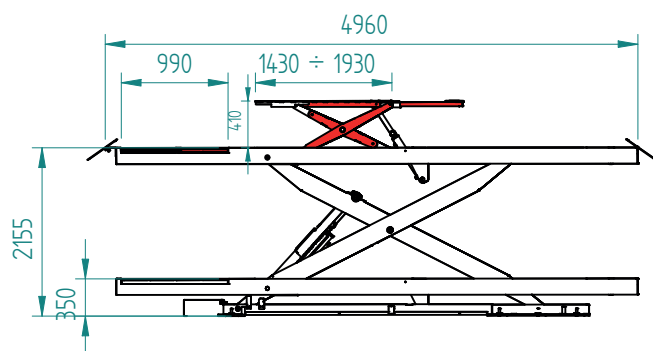

# S 500 SA

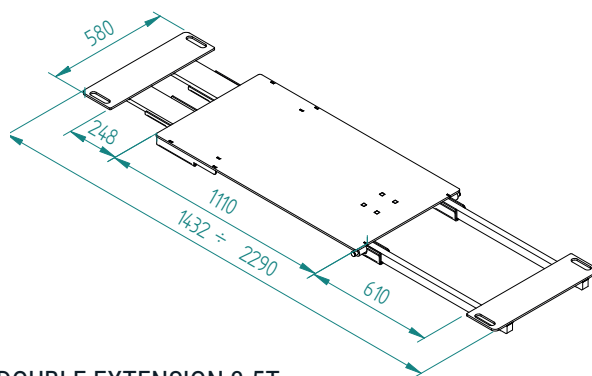
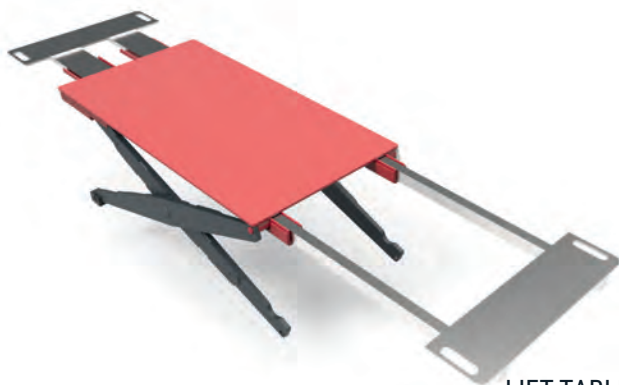
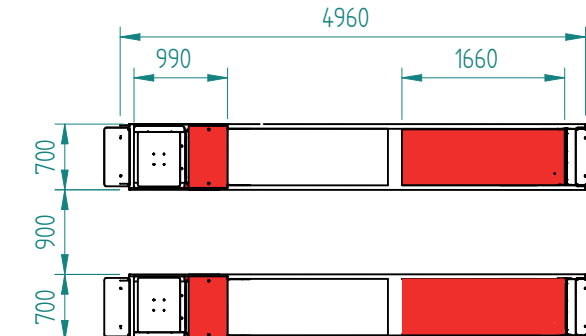
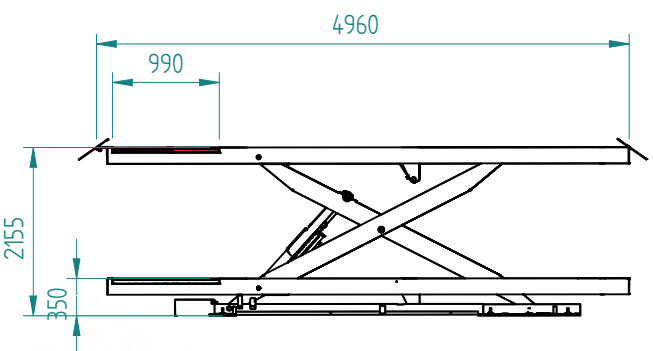

LIFT TABLE DOUBLE EXTENSION 3.5T  
DOPPIE ESTENSIONI TORRETTA 3.5T

# S 500 F

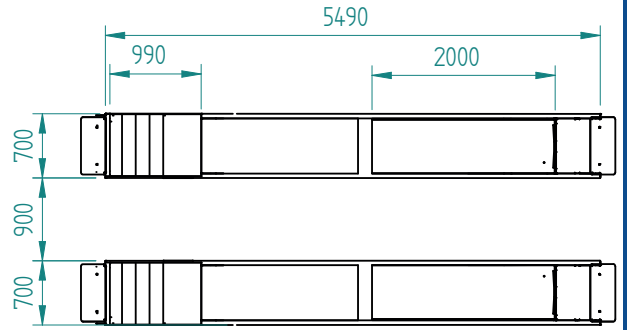
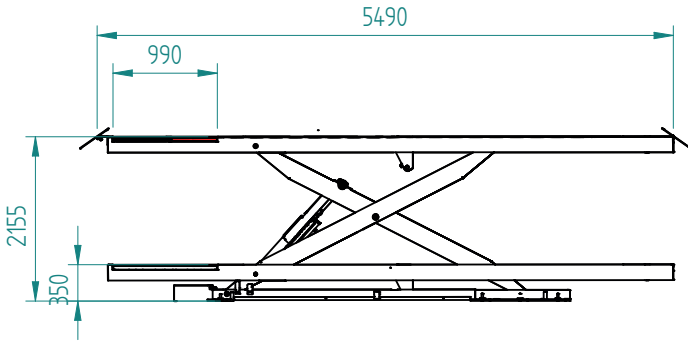

# S 500 SF

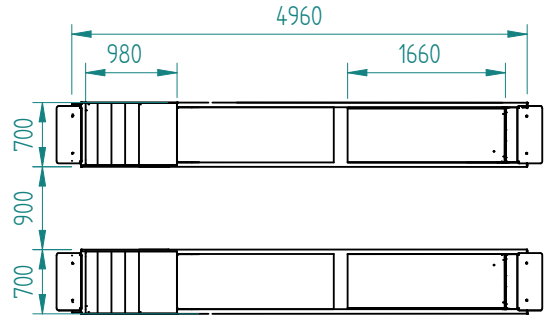
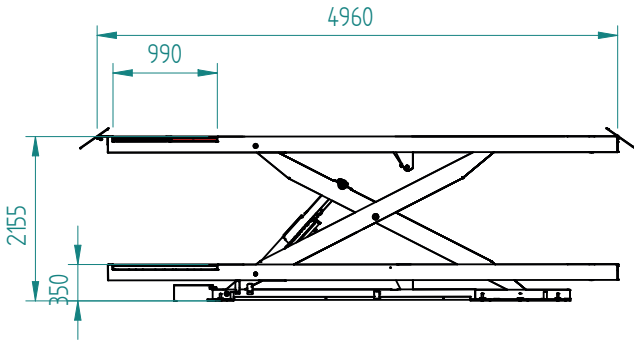

# S 500 FLT

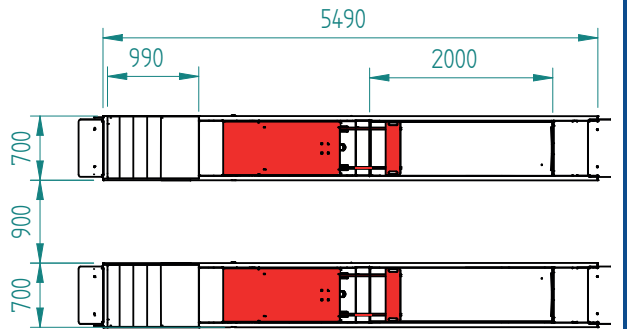
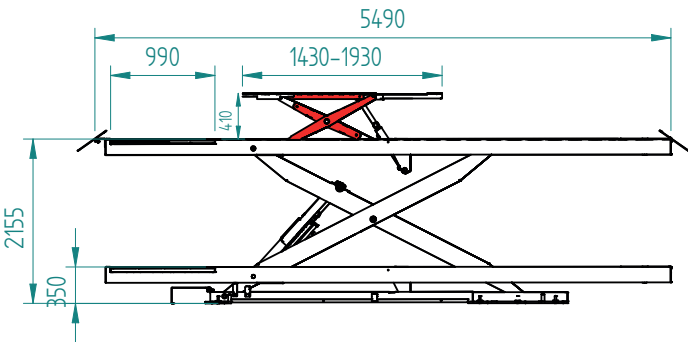

# S 500 SFLT

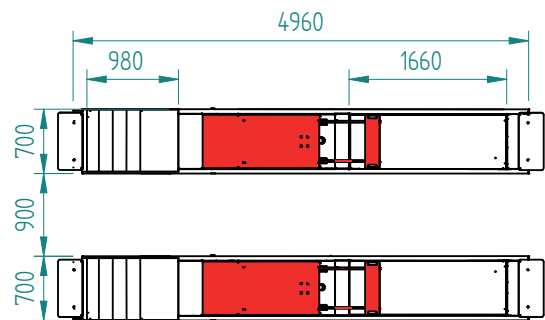
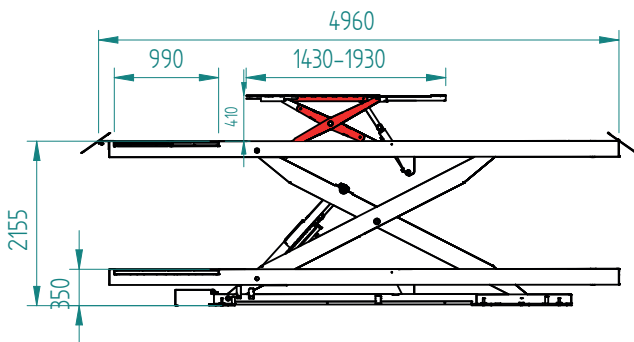

# OVERFLOOR

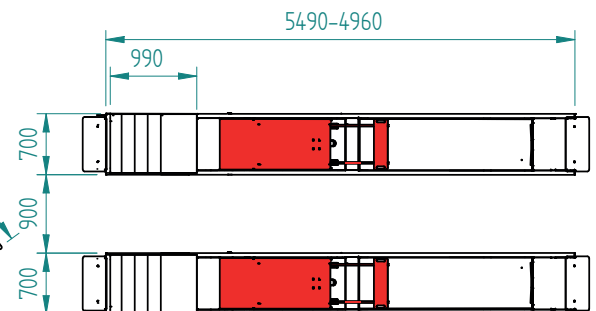
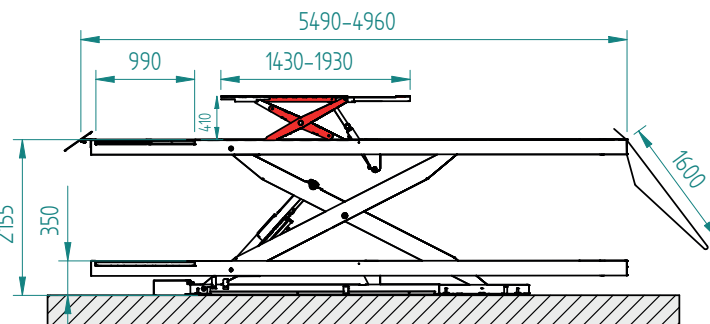

# OPTIONAL

| CODE           | DESCRIPTION  |   |     |      |      |
|----------------|--|---|-----|------|------|
| <b>A-93013</b> | LED lamps 24 Volt - Set 4 lampade 24 Volt LED  |   |     |      |      |
| <b>A-93029</b> | Expansion bolts set (20 pz) - Set tasselli di fissaggio (20pz)   |   |     |      |      |
| <b>A-93015</b> | Approaching ramps on ground installation - Set rampe salita per versione a pavimento   |   |     |      |      |
| <b>A-93030</b> | Mobile Cover for HPD - Coperture MOBILE vano HPD   |   |     |      |      |
| <b>A-93031</b> | Mobile Cover for TURNING PLATES - Coperture MOBILE vano PIATTI ROTANTI   |   |     |      |      |
| <b>A-93019</b> | Set rubber pad H= 60 mm (4 pz) - Set tamponi H= 60 mm (4 pz)   |   |     |      |      |
| <b>A-93020</b> | Set rubber pad H= 120 mm (4 pz) - Set tamponi H= 120 mm (4 pz)   |   |     |      |      |
| <b>A-93024</b> | HPD 6 movements + spot light - HPD 6 movimenti + torcia  |   |     |      |      |
| <b>A-93032</b> | Turning plates set with covers - Set piatti rotanti con copertura  |   |     |      |      |
| <b>A-93021</b> | Wires-pipes extension set L= +1 m<br>Set estensioni tubi-cavi L= +1 m  | A   | F   | SA   | SF   |
| <b>A-93022</b> | Wires-pipes extension set L= +2 m<br>Set estensioni tubi-cavi L= +2 m  | A   | F   | SA   | SF   |
| <b>A-93023</b> | Wires-pipes extension set L= +3 m<br>Set estensioni tubi-cavi L= +3 m  | A   | F   | SA   | SF   |
| <b>A-93026</b> | Wires-pipes extension set L= +1 m<br>Set estensioni tubi-cavi L= +1 m  | ALT   | FLT | SALT | SFLT |
| <b>A-93027</b> | Wires-pipes extension set L= +2 m<br>Set estensioni tubi-cavi L= +2 m  | ALT   | FLT | SALT | SFLT |
| <b>A-93028</b> | Wires-pipes extension set L= +3 m<br>Set estensioni tubi-cavi L= +3 m  | ALT   | FLT | SALT | SFLT |
| <b>A-93039</b> | Rubber ramps H=30mm<br>Rampe in gomma H=30mm   | ONLY FOR ON FLOOR VERSION / SOLO PER VERSIONE A PAVIMENTO |     |      |      |
| <b>A-93040</b> | Rubber ramps H=50mm<br>Rampe in gomma H=50mm   | ONLY FOR ON FLOOR VERSION / SOLO PER VERSIONE A PAVIMENTO |     |      |      |
| <b>A-93045</b> | recessed structure 5400mm version<br>struttura per incasso versione 5400mm   |   |     |      |      |
| <b>A-93046</b> | recessed structure 4960mm version<br>struttura per incasso versione 4960mm   |   |     |      |      |
| <b>A-93047</b> | control unit from right to left position<br>centralina da posizione destra a sinistra  |   |     |      |      |
| <b>A-93048</b> | control unit from right to left position with lift table<br>centralina da posizione destra a sinistra con lift table                     |   |     |      |      |
| <b>A-93049</b> | control unit from right to left without lift table but with HPD<br>centralina da posizione destra a sinistra senza lift table ma con HPD |   |     |      |      |
| <b>A-93050</b> | control unit from right to left position with lift table and HPD<br>centralina da posizione destra a sinistra con lift table e HPD       |   |     |      |      |

## TURNING PLATES-PIATTI ROTANTI

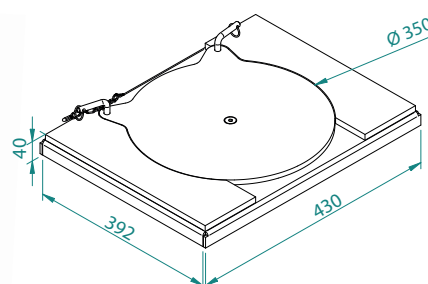
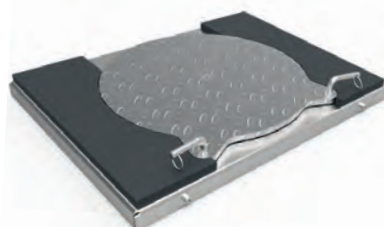



SLIDING PLATES  
PIANI OSCILLANTI



HPD 6 MOVEMENTS  
PROVAGIOCHI 6 MOVIMENTI

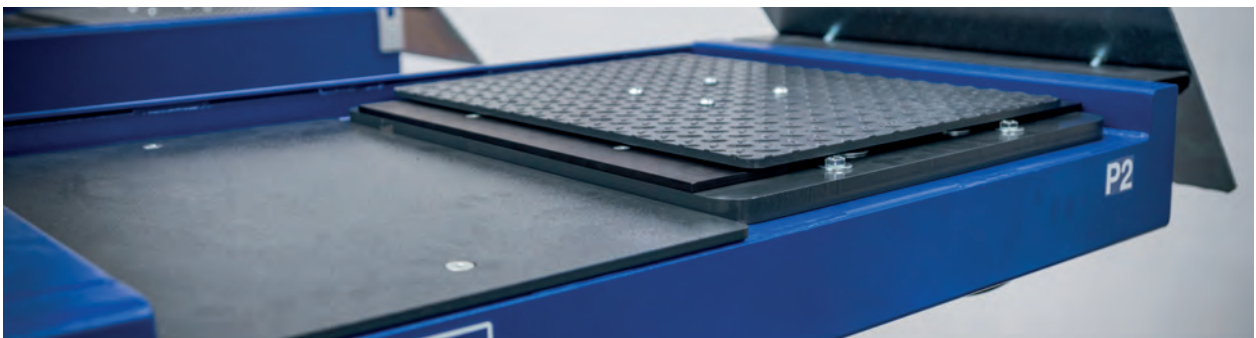

SLIDING PADS  
PATTINI DI SCORRIMENTO



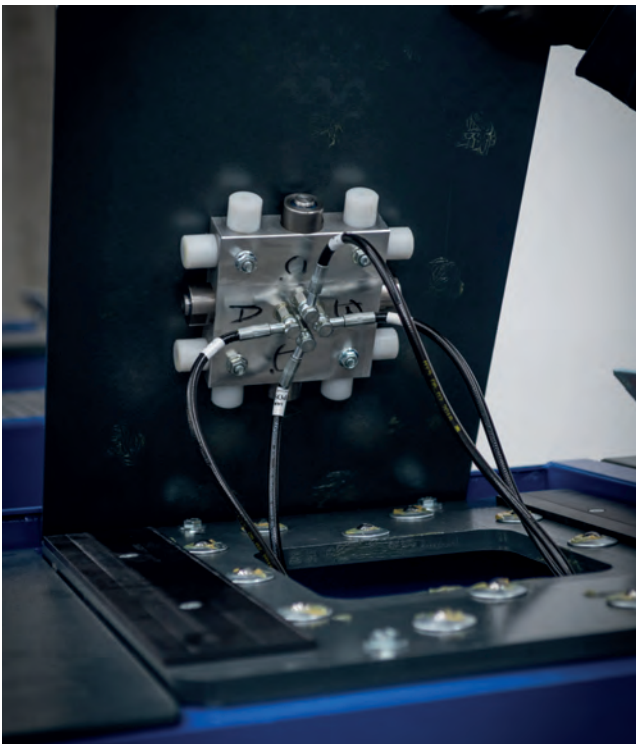



# GT-S 600

**6.000 Kg**

 Ponte elettroidraulico a forbice da assetto

 Electro-hydraulic scissor lift bridge

 Elektrohydraulische Scherenhebebrücke

 Pont élévateur électro-hydraulique à ciseaux

 Puente elevador de tijera electrohidráulico



| DATI TECNICI              | TECHNICAL DATA          | TECHISCHE DATEN           | DONNÉES TECHNIQUES             |    |                     |
|---------------------------|-------------------------|---------------------------|--------------------------------|----|---------------------|
| Portata max.              | Max. capacity           | Max. Tragfähigkeit        | Portée max.                    | kg | 6000                |
| Portata max. LT           | Max. capacity LT        | Max. Tragfähigkeit LT     | Portée max. LT                 | kg | 4000                |
| Tempo di salita / discesa | Lifting / lowering time | Hubfahrt- / Senkfahrdauer | Temps de montée / descente     | s  | 60/55               |
| Alimentazione             | Power supply            | Stromversorgung           | Alimentation                   |    | 400V 3ph 50-60Hz    |
| Potenza motore            | Electric motor power    | Motorleistung             | Puissance du moteur            | kW | 2.6 (400V 3ph 50Hz) |
| Altezza sollevamento      | Lift height             | Höhe Aufzug               | Altura ascensor                | mm | 350-2155            |
| Tensione circuito comandi | Circuit voltage command | Leerlaufspannung Befehl   | Circuit de commande de tension | V  | 24                  |



- Parallelismo idraulico pedane e torrette
- Sicurezza idraulica in caso di sovraccarico
- Sicurezza idraulica/meccanica in caso di rottura tubi
- Pompa manuale di emergenza (OPTIONAL)
- Comandi uomo presente, 24V
- Serie 4 tamponi in gomma (ALT e SALT)

- Hydraulic parallelism of platforms and turrets
- Hydraulic safety in case of overload
- Hydraulic / mechanical safety in case of pipe breakage
- Emergency manual pump (OPTIONAL)
- Dead man controls, 24V
- Series 4 rubber pads (ALT and SALT)

- Hydraulische Parallelität von Plattformen und Türmen
- Hydraulische Sicherheit bei Überlastung
- Hydraulische / mechanische Sicherheit bei Rohrbruch
- Manuelle Notpumpe (OPTIONAL)
- Totmannkontrollen, 24V
- Gummipads der Serie 4 (ALT und SALT)

- Parallélisme hydraulique des plates-formes et tourelles
- Sécurité hydraulique en cas de surcharge
- Sécurité hydraulique / mécanique en cas de rupture de canalisation
- Pompe manuelle d'urgence (EN OPTION)
- Commandes homme mort, 24V
- Patins en caoutchouc série 4 (ALT et SALT)

- Paralelismo hidráulico de plataformas y torretas.
- Seguridad hidráulica en caso de sobrecarga.
- Seguridad hidráulica / mecánica en caso de rotura de tubería
- Bomba manual de emergencia (OPCIONAL)
- Controles de hombre muerto, 24V
- Serie 4 almohadillas de goma (ALT - SALT)

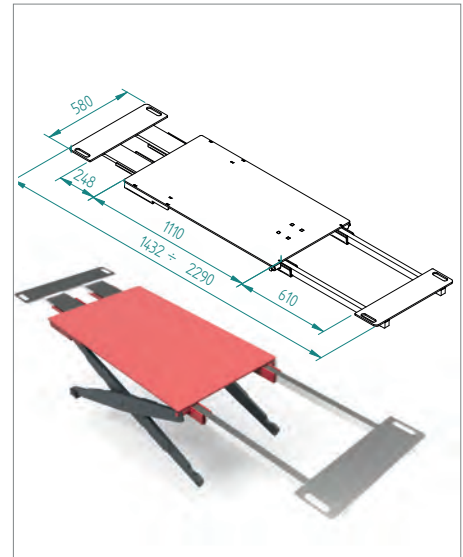

CONTROL UNIT  
CONTROL UNIT



LIFT TABLE EXTENSION 3.5T  
ESTENSIONI TORRETTE 3.5T

LIFT TABLE DOUBLE EXTENSION 3.5T  
DOPPIE ESTENSIONI TORRETTE 3.5T



4 LED LIGHTS  
4 LUCI A LED



APPROACHING RAMPS 1600mm  
RAMPE SALITA 1600mm



SLIDING PLATES  
PIANI OSCILLANTI



PIATTO ROTANTE  
ROTATING PLATE



HPD 6 MOVEMENTS  
PROVA GIOCHI 6 MOVIMENTI

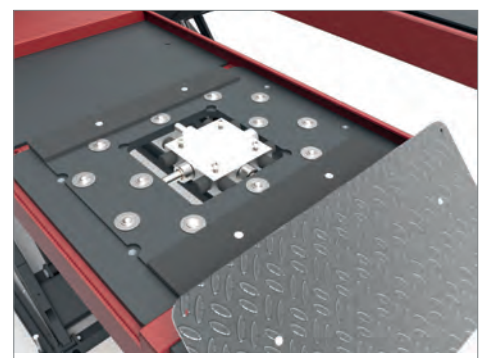

# S 600 ALT

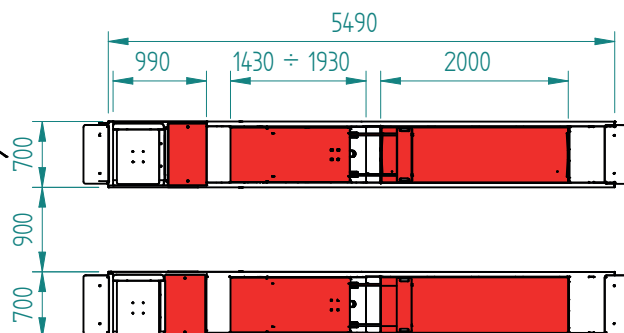
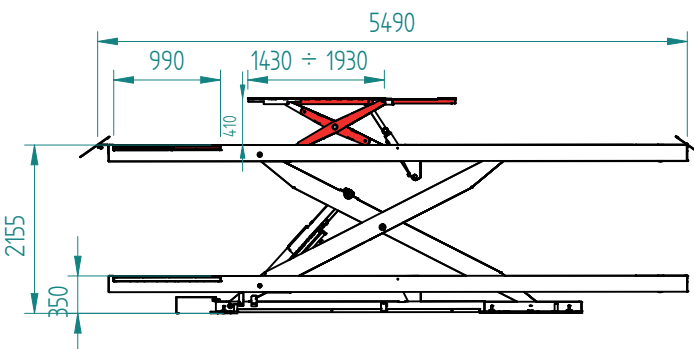

# S 600 A

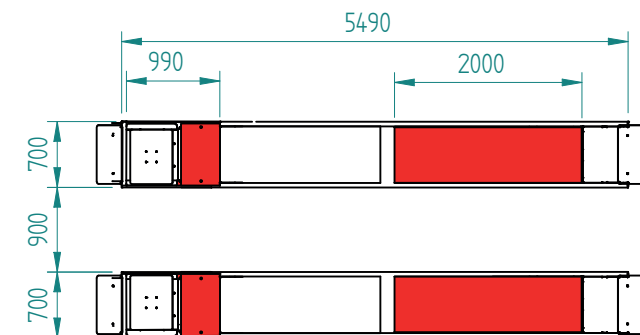
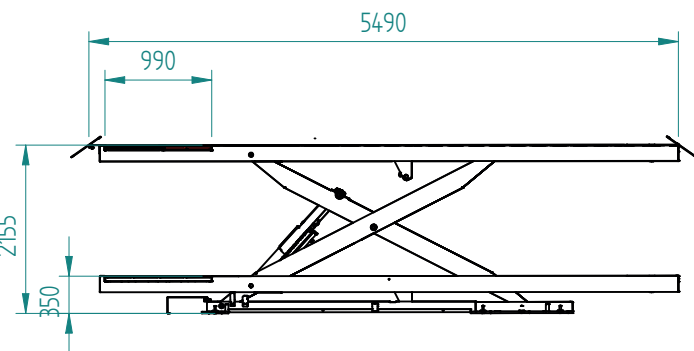



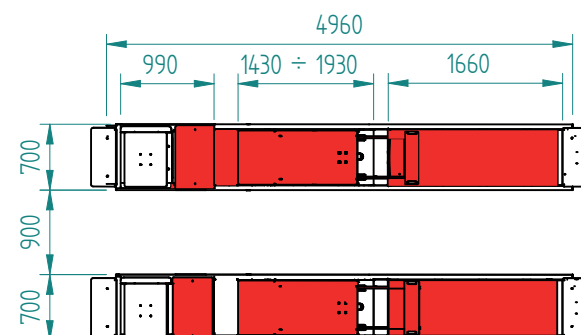
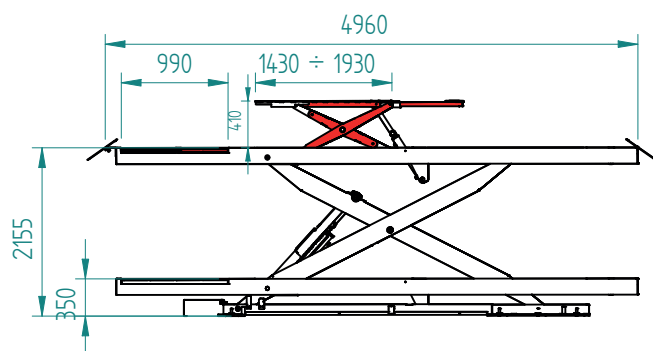

# S 600 SALT

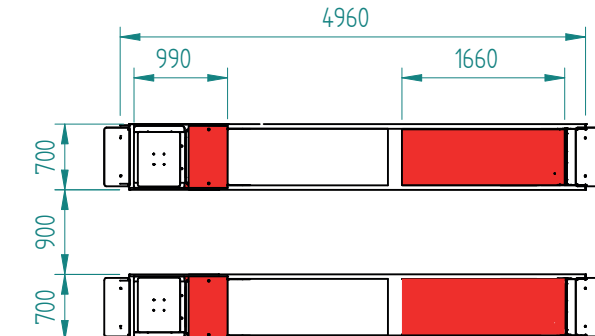
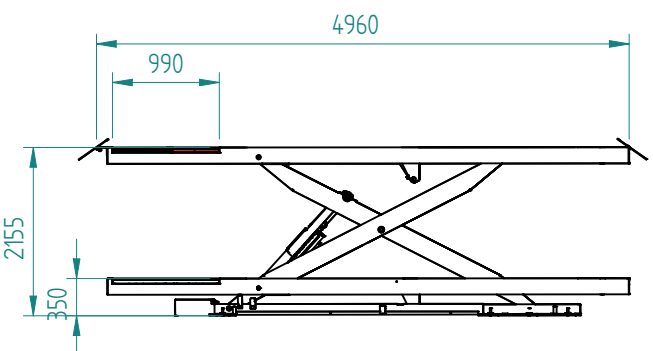

# S 600 SA



-  • BIELLE RINFORZATE INTERNAMENTE ED ESTERNAMENTE
-  • CONNECTING RODS REINFORCED INTERNALLY AND EXTERNALLY
-  • TIGES DE CONNEXION RENFORCÉES INTERNE ET EXTÉRIEUREMENT
-  • VERBINDUNGSSTANGEN INTERN UND EXTERN VERSTÄRKT
-  • MATERIAL SEGURO MECÁNICO EN ACERO ESPECIAL

# S 600 F

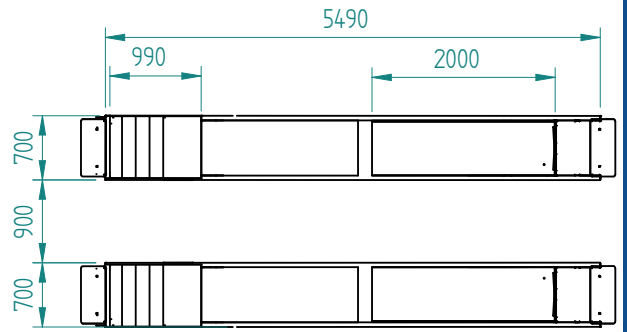
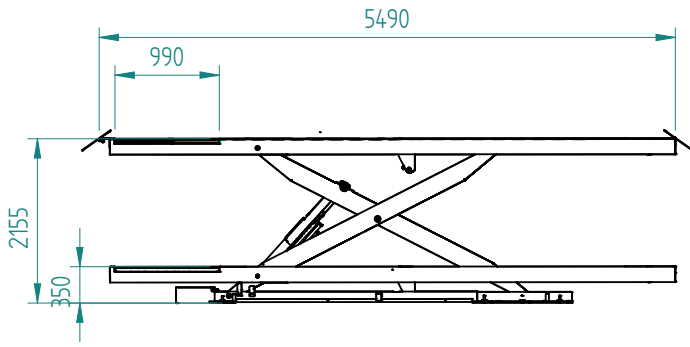

# S 600 SF

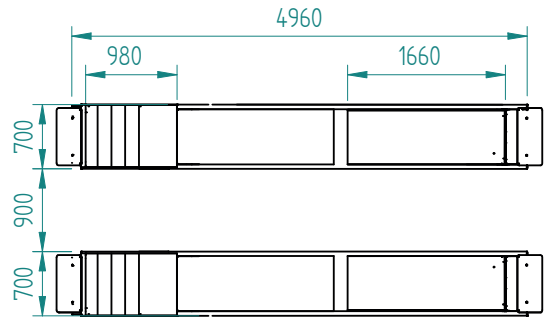
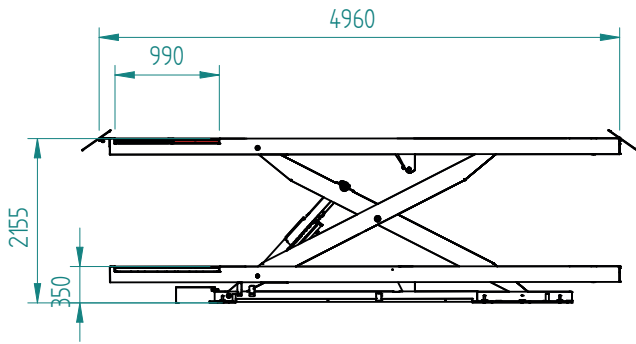

# S 600 FLT

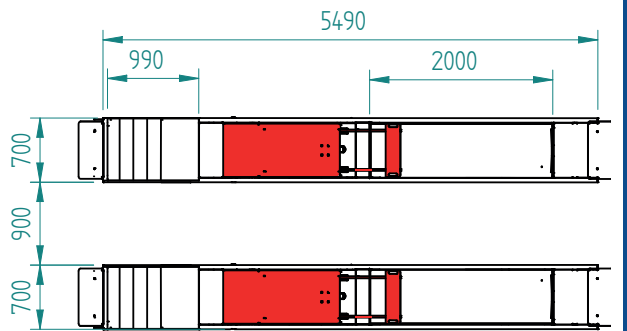
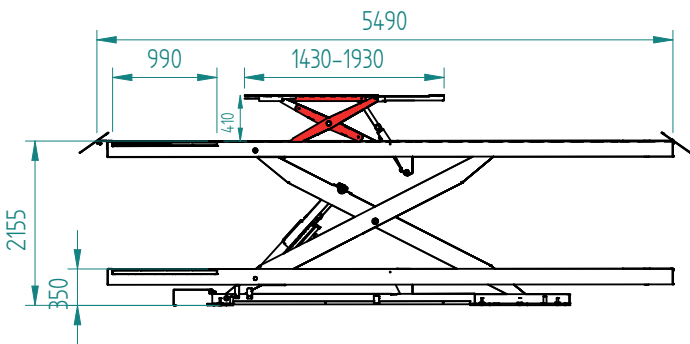

# S 600 SFLT

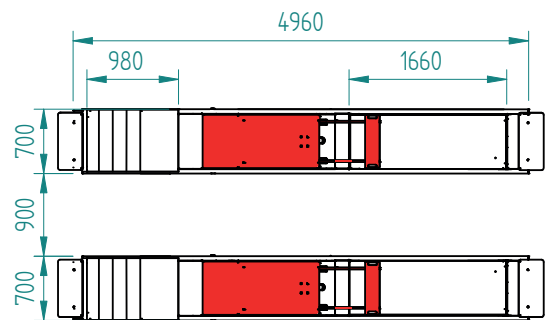
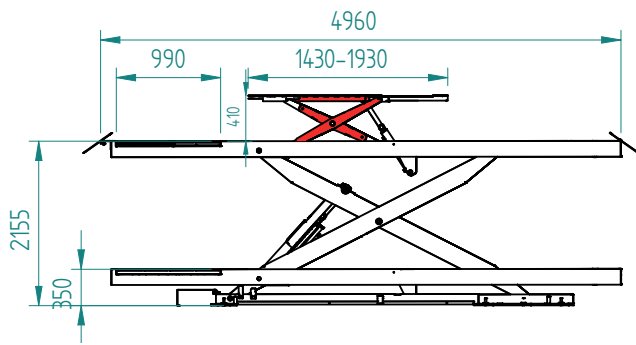

# OVERFLOOR

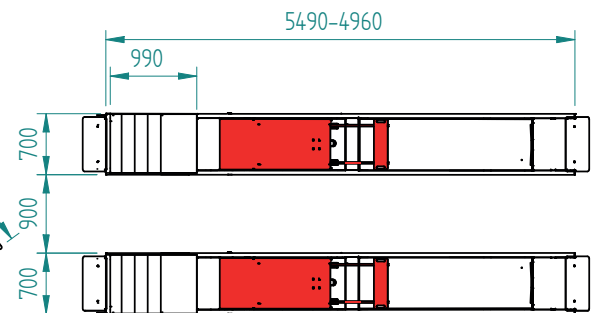
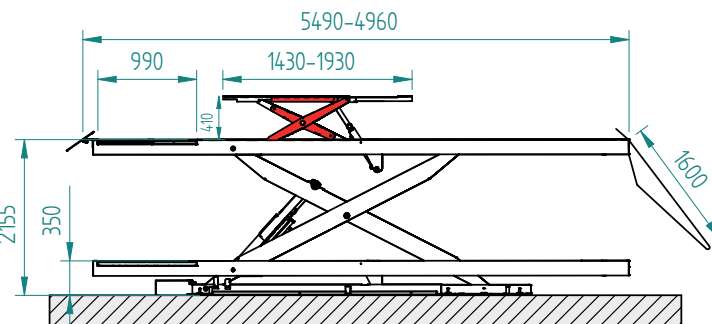

# OPTIONAL

| CODE           | DESCRIPTION  |   |     |      |      |
|----------------|--|---|-----|------|------|
| <b>A-93013</b> | LED lamps 24 Volt - Set 4 lampade 24 Volt LED  |   |     |      |      |
| <b>A-93029</b> | Expansion bolts set (20 pz) - Set tasselli di fissaggio (20pz)   |   |     |      |      |
| <b>A-93015</b> | Approaching ramps on ground installation - Set rampe salita per versione a pavimento   |   |     |      |      |
| <b>A-93030</b> | Mobile Cover for HPD - Coperture MOBILE vano HPD   |   |     |      |      |
| <b>A-93031</b> | Mobile Cover for TURNING PLATES - Coperture MOBILE vano PIATTI ROTANTI   |   |     |      |      |
| <b>A-93019</b> | Set rubber pad H= 60 mm (4 pz) - Set tamponi H= 60 mm (4 pz)   |   |     |      |      |
| <b>A-93020</b> | Set rubber pad H= 120 mm (4 pz) - Set tamponi H= 120 mm (4 pz)   |   |     |      |      |
| <b>A-93024</b> | HPD 6 movements + spot light - HPD 6 movimenti + torcia  |   |     |      |      |
| <b>A-93032</b> | Turning plates set with covers - Set piatti rotanti con copertura  |   |     |      |      |
| <b>A-93021</b> | Wires-pipes extension set L= +1 m<br>Set estensioni tubi-cavi L= +1 m  | A   | F   | SA   | SF   |
| <b>A-93022</b> | Wires-pipes extension set L= +2 m<br>Set estensioni tubi-cavi L= +2 m  | A   | F   | SA   | SF   |
| <b>A-93023</b> | Wires-pipes extension set L= +3 m<br>Set estensioni tubi-cavi L= +3 m  | A   | F   | SA   | SF   |
| <b>A-93026</b> | Wires-pipes extension set L= +1 m<br>Set estensioni tubi-cavi L= +1 m  | ALT   | FLT | SALT | SFLT |
| <b>A-93027</b> | Wires-pipes extension set L= +2 m<br>Set estensioni tubi-cavi L= +2 m  | ALT   | FLT | SALT | SFLT |
| <b>A-93028</b> | Wires-pipes extension set L= +3 m<br>Set estensioni tubi-cavi L= +3 m  | ALT   | FLT | SALT | SFLT |
| <b>A-93039</b> | Rubber ramps H=30mm<br>Rampe in gomma H=30mm   | ONLY FOR ON FLOOR VERSION / SOLO PER VERSIONE A PAVIMENTO |     |      |      |
| <b>A-93040</b> | Rubber ramps H=50mm<br>Rampe in gomma H=50mm   | ONLY FOR ON FLOOR VERSION / SOLO PER VERSIONE A PAVIMENTO |     |      |      |
| <b>A-93045</b> | recessed structure 5400mm version<br>struttura per incasso versione 5400mm   |   |     |      |      |
| <b>A-93046</b> | recessed structure 4960mm version<br>struttura per incasso versione 4960mm   |   |     |      |      |
| <b>A-93047</b> | control unit from right to left position<br>centralina da posizione destra a sinistra  |   |     |      |      |
| <b>A-93048</b> | control unit from right to left position with lift table<br>centralina da posizione destra a sinistra con lift table                     |   |     |      |      |
| <b>A-93049</b> | control unit from right to left without lift table but with HPD<br>centralina da posizione destra a sinistra senza lift table ma con HPD |   |     |      |      |
| <b>A-93050</b> | control unit from right to left position with lift table and HPD<br>centralina da posizione destra a sinistra con lift table e HPD       |   |     |      |      |

## TURNING PLATES-PIATTI ROTANTI

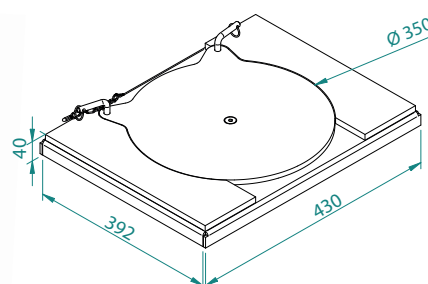
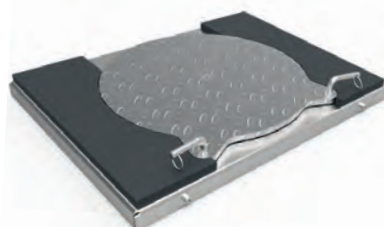



SLIDING PLATES  
PIANI OSCILLANTI



HPD 6 MOVEMENTS  
PROVAGIOCHI 6 MOVIMENTI

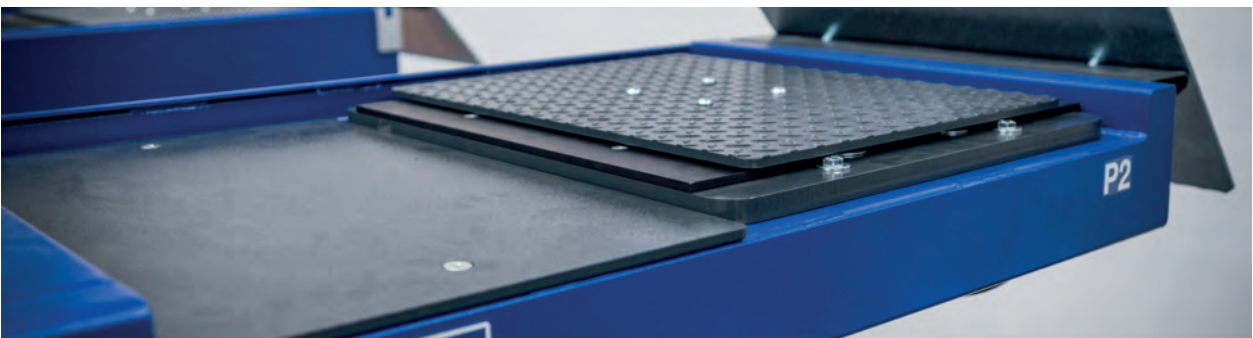

SLIDING PADS  
PATTINI DI SCORRIMENTO





# GALTA

Vat. n° 04058700248

Via Vittorio Lombardi 19/21 - 36075 Montecchio Maggiore (VI) Italy

Phone : +39 0444 493977 - Fax: +39 0444 495999

[www.galta.it](http://www.galta.it) - [info@galta.it](mailto:info@galta.it)

